

(16) DCS Band Low Pass Filter (SCI-202 W/F)

FEATURES

- Passive integration on silicon substrate
- Low insertion loss in pass band
- Small size: 1.5 mm x 0.8 mm (wirebond)
1.6 mm x 1.0 mm (flip chip)
- Pb-free solder bump
- Low profile: 0.25 mm height (wirebond)
0.40 mm height (flip chip)
- Directly attachable on PCB or flipped on PCB
- Operating temperature: -40°C to +85°C
- Storage temperature: -40°C to +85°C

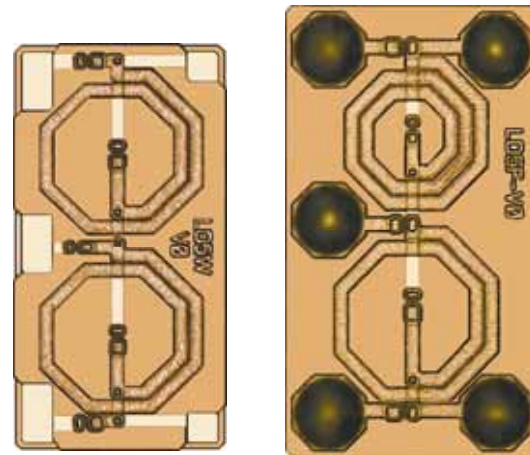

SCI-202W (Wirebond)

SCI-202F (Flip Chip)

DESCRIPTION

STATS ChipPAC's SCI-202W/F is a low pass filter (LPF) for DCS band applications. The LPF has low pass-band insertion loss and small size. It is composed of thick copper inductors and Metal-Insulator-Metal capacitors which are fabricated on a silicon substrate using STATS ChipPAC's IPD (Integrated Passive Device) process. The pad or bump size and pitch of the LPF are selected so that the device can be mounted directly on a PCB or laminate substrate using conventional wire-bonding or surface mount techniques. The low profile and small form-factor of the device make it especially suitable for SiP applications.

ELECTRICAL SPECIFICATIONS

Specification	Unit	Min.	Typical	Max.
Pass Band	MHz	1710		1980
Insertion Loss	dB		0.4	
Return Loss	dB	15		20
Attenuation, 2f ₀	dB		30	
Attenuation, 3f ₀	dB		30	
Size	mm	1.5 x 0.8 (WB)		1.6 x 1.0 (FC)

DIMENSIONS

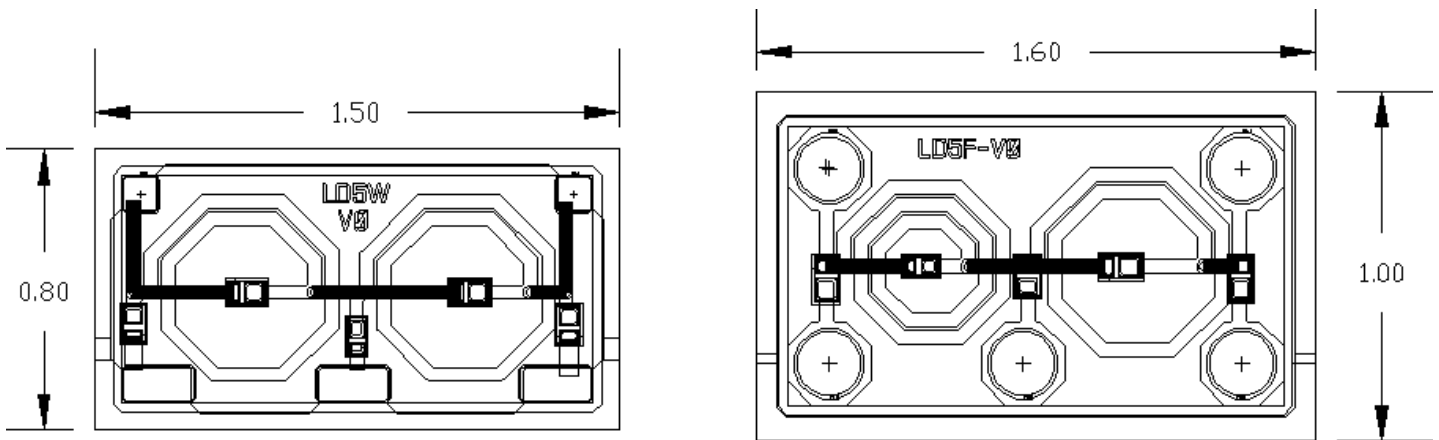

TYPICAL CHARACTERISTICS

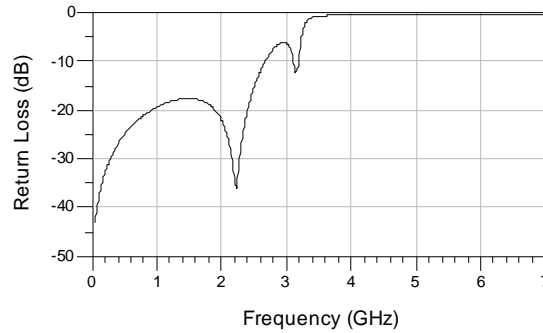
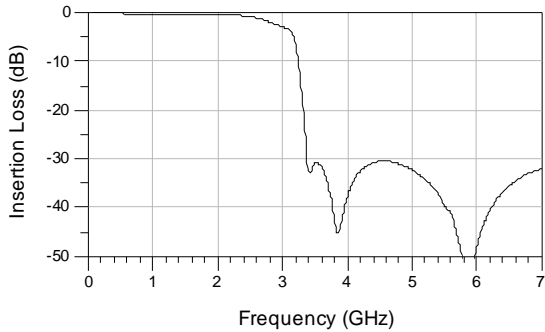

ASSEMBLY DRAWING / MECHANICAL OUTLINE

SCI-202W (Wirebond)

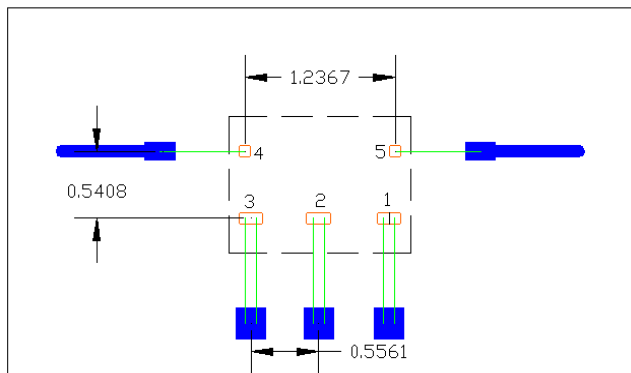

SCI-202F (Flip Chip)

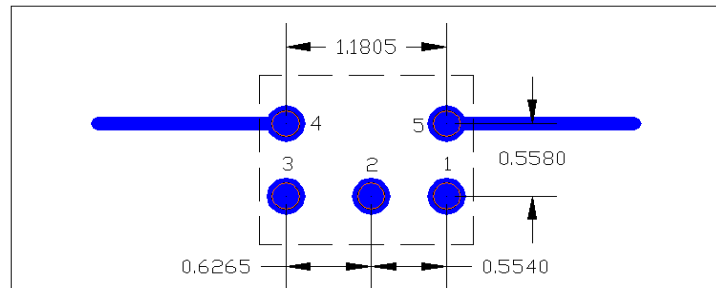

Pad	SCI-202W Signal	SCI-202F Signal
1	Ground	Ground
2	Ground	Ground
3	Ground	Ground
4	Input	Output
5	Output	Input

NOTES

All dimension measurement units are in millimeters (mm). Electrical performance and typical values are measured at room temperature. For best results, ground plane directly beneath the device should be in the top metal layer.

Refer to "Appendix A" for:

- Pad sizes and typical wirebond length used in the wirebonded IPD products.
- Recommended solder thermal profile, landing pattern recommendation and bump specifications used in the flip chip IPD products.